

Mealy and Moore Machines

ECE 152A – Summer 2009

Reading Assignment

- Brown and Vranesic
 - 8 Synchronous Sequential Circuits
 - 8.3 Mealy State Model

Reading Assignment

- Roth

- 13 Analysis of Clocked Sequential Circuits
 - 13.1 A Sequential Parity Checker
 - 13.2 Analysis by Signal Tracing and Timing Charts
 - 13.3 State Tables and Graphs
 - 13.4 General Models for Sequential Circuits

Finite State Machines

- Thus far, sequential circuit (counter and register) outputs limited to state variables
- In general, sequential circuits (or Finite State Machines, FSM's) have outputs in addition to the state variables
 - For example, vending machine controllers generate output signals to dispense product, provide change, illuminate displays, etc.

Finite State Machines

- Two types (or models) of sequential circuits (or finite state machines)
 - Mealy machine
 - Output is function of present state and present input
 - Moore machine
 - Output is function of present state only
- Analysis first, then proceed to the design of general finite state machines

Analysis by Signal Tracing and Timing Diagrams

- Timing Analysis
 - Determine flip-flop input equations
 - Determine output equations
 - Mealy or Moore model
 - Generate timing diagram illustrating circuit's response to a particular input sequence
 - Outputs as well as to state

Moore Network Example

- Implemented with falling edge triggered (by way of external inverter) JK flip-flops
- Schematic (following slide)
 - $J_A = x \quad K_A = xB'$
 - $J_B = x \quad K_B = x \text{ XOR } A' = xA + x'A'$
 - $z = B$ (function of present state only)

August 3, 2009

ECE 152A - Digital Design Principles

7

Moore Network Example

- Schematic

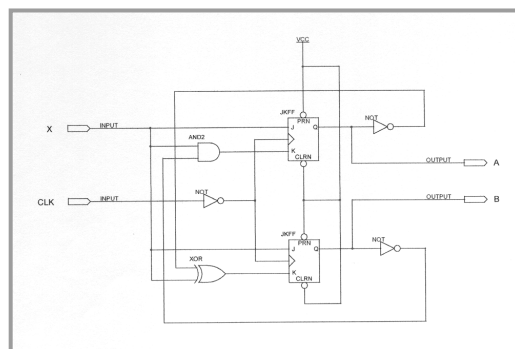

August 3, 2009

ECE 152A - Digital Design Principles

8

Moore Network Example

■ Timing Diagram and Analysis

- Initial conditions:
 - $A = B = z = 0$
- Input sequence:
 - $x = 10101$
- All state and output transitions occur after the falling clock edge
 - Assumes x changes on rising edge
 - Best case assumption for satisfying setup and hold time

Moore Network Example

■ Timing Diagram (Functional Simulation)

$$\begin{array}{ll}
 J_A = x & K_A = xB' \\
 J_B = x & K_B = x \text{ XOR } A' = xA + x'A' \\
 & z = B
 \end{array}$$

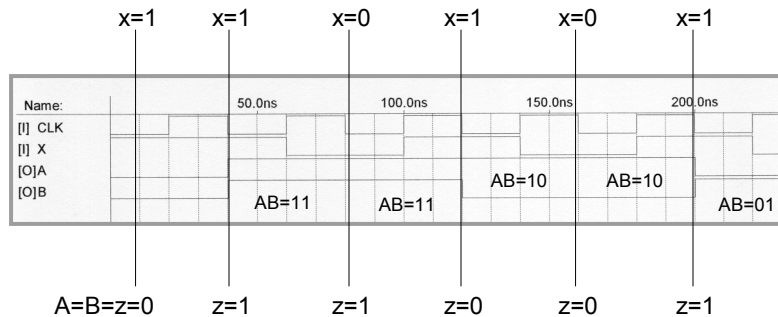

Mealy Network Example

■ Timing Diagram and Analysis

- Initial conditions:
 - $A = B = 0$
 - $z = 1$
- Input sequence:
 - $x = 10101$
- Analysis again assumes x changes on rising edge of clock
- All state transitions occur after the falling clock edge (as with Moore machine)

Mealy Network Example

■ Timing Diagram and Analysis (cont)

- Output transitions occur in response to both input and state transitions
 - “glitches” may be generated by transitions in inputs
 - Moore machines don’t glitch because outputs are associated with present state only
- Assumes gate delays to output(s) much shorter than clock period
 - All outputs stable before occurrence of active clock edge

Mealy Network Example

■ Timing Diagram (Timing Simulation)

$$\begin{aligned} J_A &= xB & K_A &= x \\ J_B &= x & K_B &= xA \\ z &= xB' + xA + x'A'B \end{aligned}$$

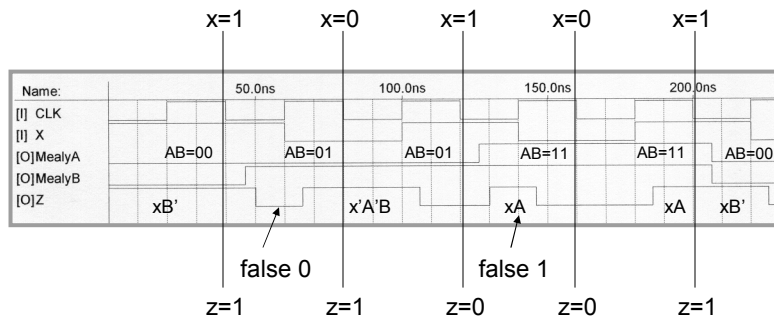

August 3, 2009

ECE 152A - Digital Design Principles

15

Mealy Machines and Glitches

- In synchronous network, glitches don't matter
 - All data transfers occur around common, falling (or rising) clock edge
 - Register transfer operations
 - Outputs sampled only on active clock edge
 - Output is stable before and after active clock edge
 - Setup and hold times satisfied

August 3, 2009

ECE 152A - Digital Design Principles

16

FSM Outputs & Timing - Summary

- For Moore machine, output is valid after state transition
 - Output associated with stable present state
- For Mealy machine, output is valid on occurrence of active clock edge
 - Output associated with transition from present state to next state
 - Output in Mealy machine occurs one clock period before output in equivalent Moore machine

Derivation of State Tables and Diagrams

- Timing diagram illustrates the sequential circuit's response to a particular input sequence
 - May not include all states and all transitions
- In general, analysis needs to produce state diagram and state table
- Reverse of design process
 - Begin with implementation, derive state diagram

Derivation of State Tables and Diagrams

- Returning to Moore machine example
 - Flip-Flop inputs and circuit output functions
 - $J_A = x$ $K_A = xB'$
 - $J_B = x$ $K_B = x \text{ XOR } A' = xA + x'A'$
 - $z = B$ (function of present state only)
- Begin with characteristic equation for JK Flip-Flop
 - $Q^+ = JQ' + K'Q$

Derivation of State Tables and Diagrams

- Using characteristic function, generate next state equations and maps for each flip flop
 - $Q^+ = JQ' + K'Q \rightarrow A^+ = J_A Q' + K_A' Q$
 - $A^+ = xA' + (xB')' A = xA' + x'A + AB$

 - $Q^+ = JQ' + K'Q \rightarrow B^+ = J_B Q' + K_B' Q$
 - $B^+ = xB' + (x \text{ xor } A')' B = xB' + xA'B + x'AB$

Derivation of State Tables and Diagrams

■ Next State Maps

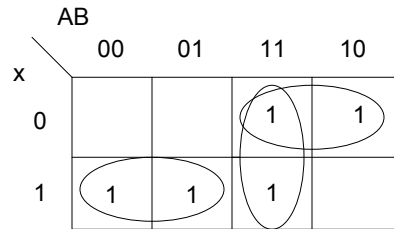

$$A^+ = xA' + x'A + AB$$

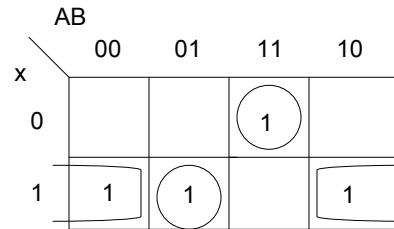

$$B^+ = xB' + xA'B + x'AB$$

Derivation of State Tables and Diagrams

■ State Table

PS	NS		z (=B)
	X=0	X=1	
AB	AB	AB	
00	00	11	0
01	00	11	1
10	10	01	0
11	11	10	1

Derivation of State Tables and Diagrams

■ State Diagram

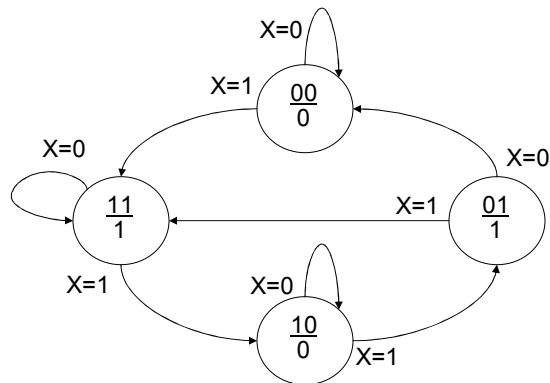

PS AB	NS		z (=B)
	X=0 AB	X=1 AB	
00	00	11	0
01	00	11	1
10	10	01	0
11	11	10	1

Derivation of State Tables and Diagrams

■ Mealy machine example

□ Flip-Flop inputs and circuit output functions

- $J_A = xB$ $K_A = x$
- $J_B = x$ $K_B = xA$
- $z = xB' + xA + x'A'B$

■ Once again, begin with characteristic Equation for JK Flip-Flop

□ $Q^+ = JQ' + K'Q$

Derivation of State Tables and Diagrams

- Generate next state equations and maps for each flip flop

$$\square Q^+ = JQ' + K'Q \rightarrow A^+ = J_A Q' + K_A' Q$$

$$\square A^+ = xBA' + x'A$$

$$\square Q^+ = JQ' + K'Q \rightarrow B^+ = J_B Q' + K_B' Q$$

$$\square B^+ = xB' + (xA)'B = xB' + x'B + A'B$$

August 3, 2009

ECE 152A - Digital Design Principles

25

Derivation of State Tables and Diagrams

- Next state and output maps

	AB			
	00	01	11	10
x			1	1
0				
1		1		

$$A^+ = xBA' + x'A$$

$$B^+ = xB' + x'B + A'B$$

$$z = xB' + xA + x'A'B$$

	AB			
	00	01	11	10
x		1	1	
0				
1	1	1		1

	AB			
	00	01	11	10
x		1		
0				
1	1		1	1

August 3, 2009

ECE 152A - Digital Design Principles

26

Derivation of State Tables and Diagrams

■ State Table

PS AB	NS	
	x=0 AB,z	x=1 AB,z
00	00,0	01,1
01	01,1	11,0
10	10,0	01,1
11	11,0	00,1

Derivation of State Tables and Diagrams

■ State Diagram

